

OP100

PLENUM FOR WALL GRILLES

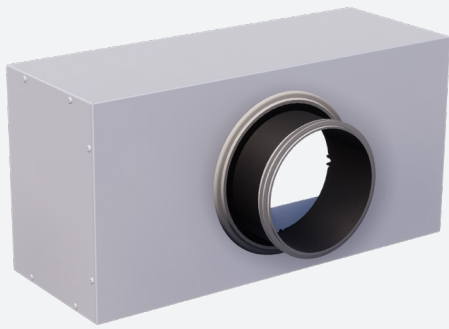
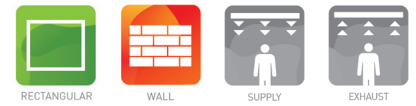

VARIANTS

OP100T, OP100A, OP100S

The OP100 plenum box is suitable for connection of rectangular wall grilles. Unlike the ceiling plenum DP100, the OP100 has no protruding clinched ribs. Instead, the sides are folded over to keep it as compact as possible. It's available in three executions: Side entry, top entry or asymmetric top entry. Flow control is possible by means of a perforated damper in the inlet spigot.

No protruding clinched ribs

Folded over sides to keep it as compact as possible

Also available with asymmetric top entry

TECHNICAL INFORMATION

APPLICATION	Type	Plenum for wall grilles
	Version	Side / Top / Top asymmetrisch
CONSTRUCTION	Shape	Rectangle
	Length	100-2000mm
	Height	38-900mm
	Depth	100-650mm
	Spigot	Ø80-400mm
	OP100	For mounting of wall grilles in combination with mounting frame GR001
OP101	Equipped with folded lip for direct mounting of wall grilles with clip fixing	
PLENUM	Material	Galvanised (275g/m ²) sheet steel, PP/TPE spigot
	Insulation (optional)	Melamine 6mm
	Spigot plenum	Class D spigot with double lip seal
	Volume control	Perforated volume control disk with manual operation (optional)
	Mounting options	Mounting straps available upon request

PRODUCT KEY

PLENUM FOR WALL GRILLES																									
0	P	1	0	0	-	T	-	-	0	0	4	0	0	0	2	0	0	0	1	5	0	0	1	0	0
										Nominal length L (mm): From 100 to 2000mm, per 1mm			Nominal height H (mm): From 38 to 900 per 1mm			Nominal depth D (mm): From 100 to 650 per 1mm			Nominal diameter N (mm): 80, 100, 125, 160, 200, 250, 315, 355 en 400						
										0: Without mounting straps 1: With mounting straps															
										- : Without damper D : With damper															
										-: Non insulated plenum G: Insulated plenum															
										S: Side connection T: Top connection A: Asymmetric															
										0: For mounting of wall grilles in combination with mounting frame GR001 1: Equipped with folded lip for direct mounting of wall grilles with clip fixing 2: Equipped with folded lip for direct mounting of wall grilles with concealed screw fixing															

DIMENSIONS

ØN	D2	E	H1
80	D - 51	52	101
100	D - 61	52	121
125	D - 83	58	165
160	D - 100	58	200
200	D - 120	58	240
250	D - 145	58	290
315	D - 169	49	338
355	D - 189	49	378
400	D - 212	49	423

D1 = 50, 75, 100, 125, of 150

All dimensions in mm

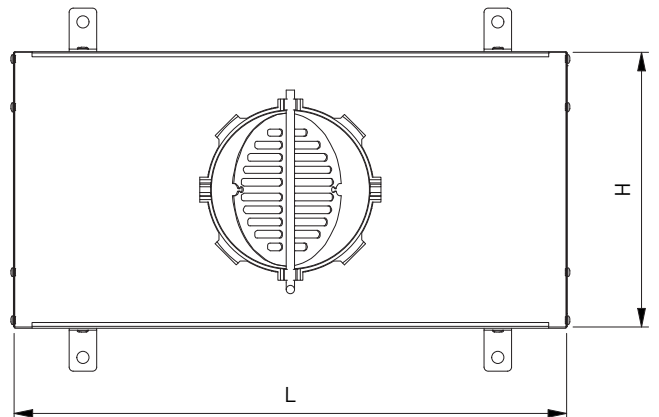
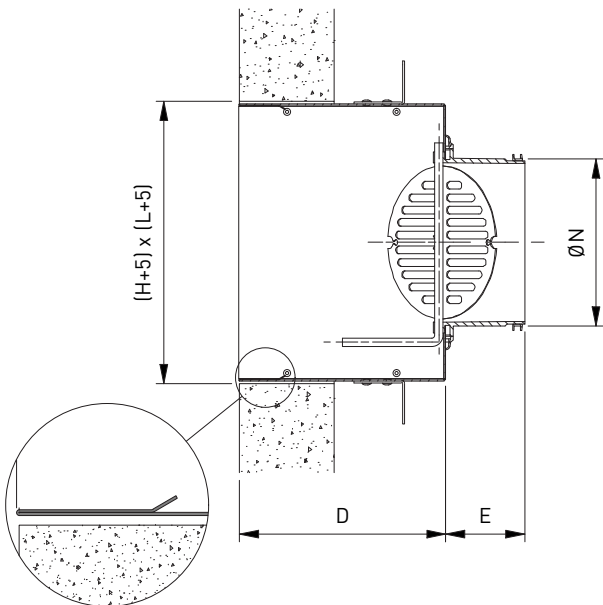
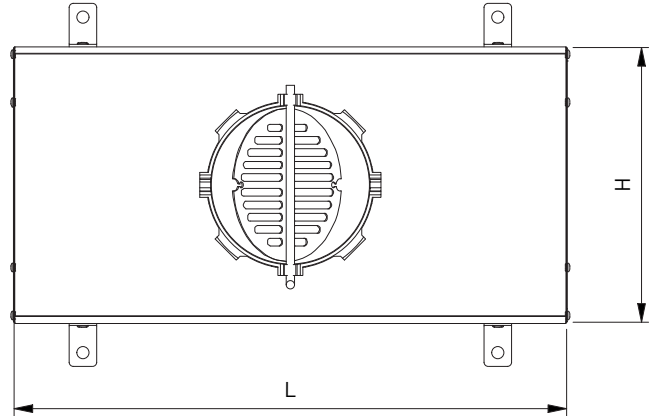
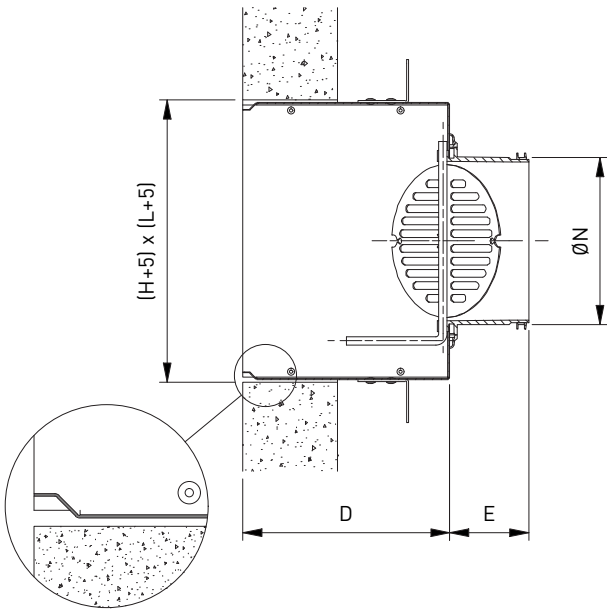
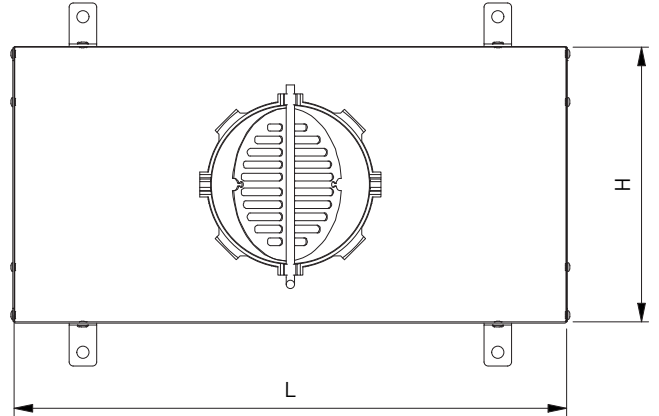
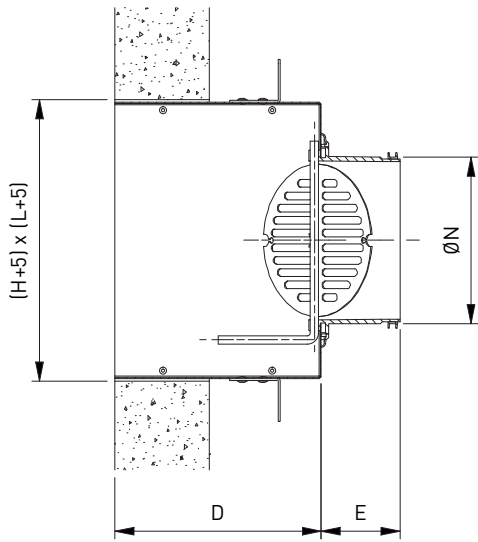

OP100-A-D1

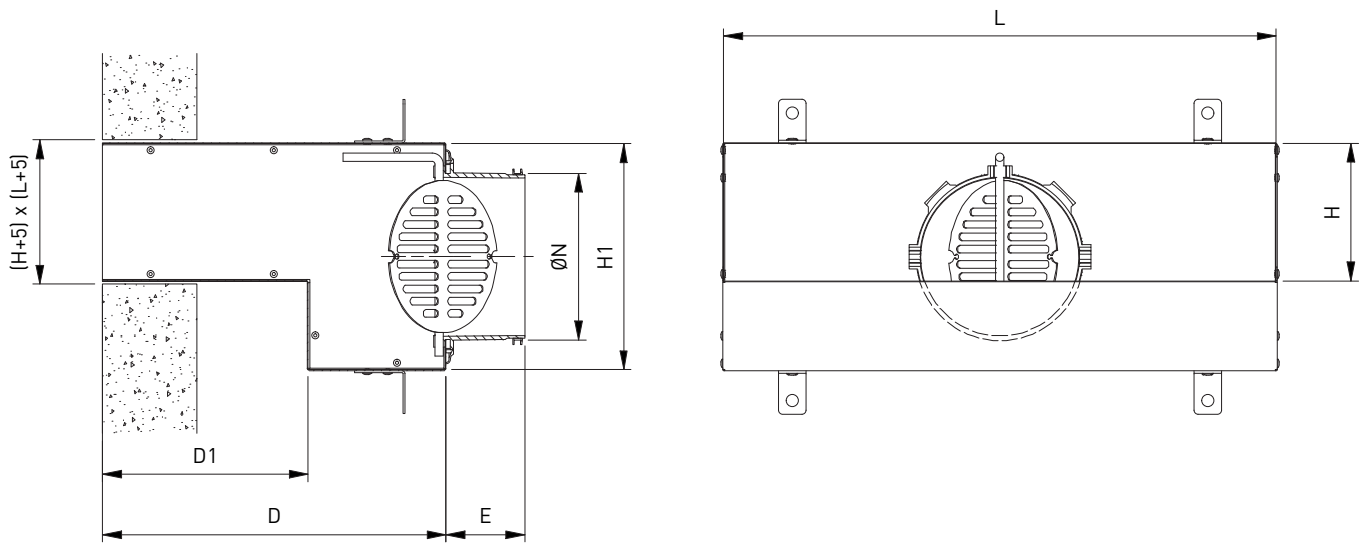

OP100-S-D1

