

**FLOOR GRILLE
VMH11**

Installation dimensions

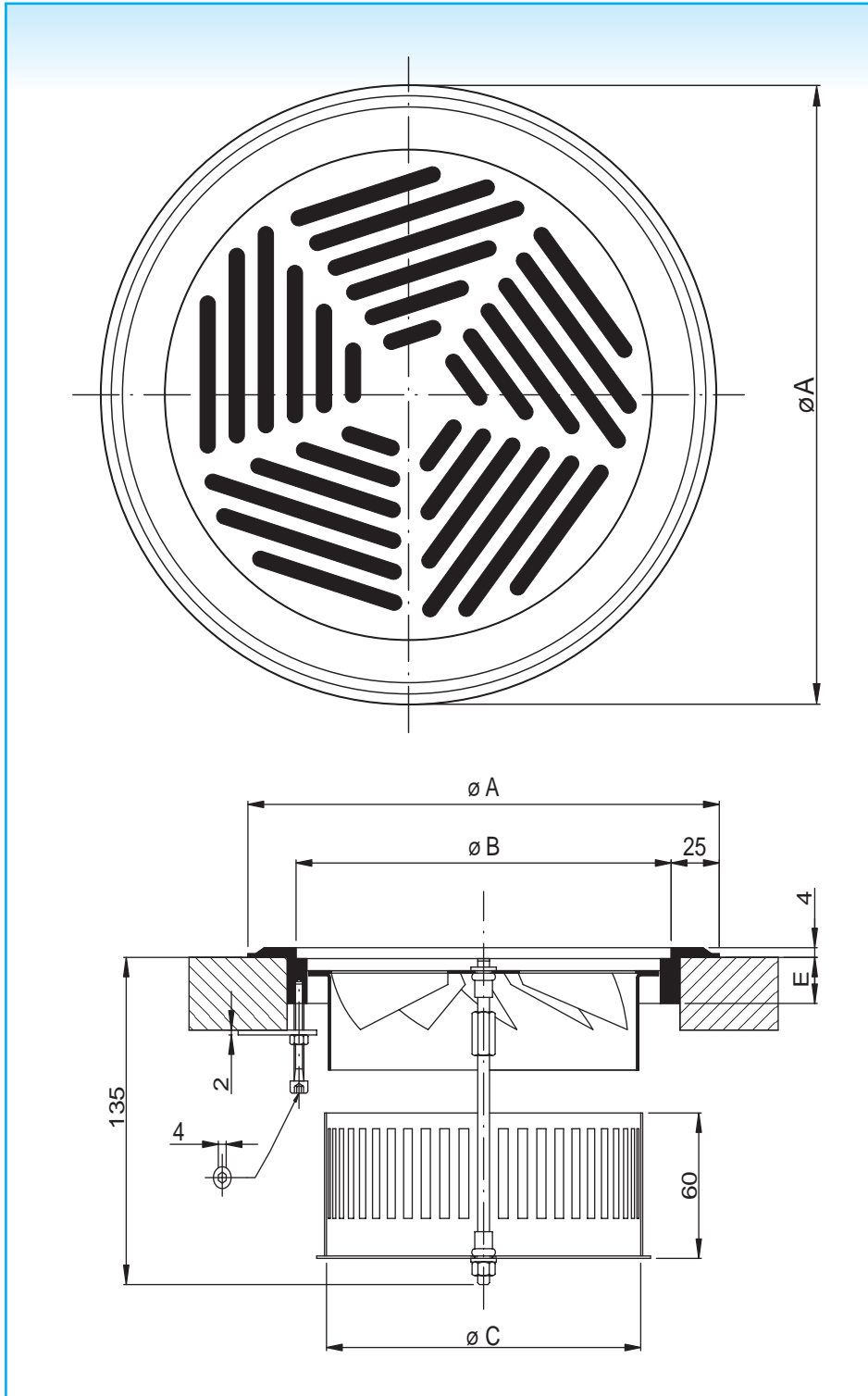

Size	$\varnothing A$	$\varnothing B$	$\varnothing C$	E
150	190	140	124	14
200	236	190	160	19

All dimensions in mm



Application

The grille type VM is used for supply and exhaust of cooled and heated air in facilities such as offices, meeting rooms, auditoria, concert halls, The grille can be mounted in the floor where an strict aesthetic construction is desired. Suitable for mounting in system floors.

Technical Information

Characteristics:

- floor grille combined with a swirl dif-fuser
- horizontal or vertical swirl-form air pattern
- removable grille tile
- with dust basket that can be used as damper
- with outer ring

Construction:

- floor grille and outer ring are made out of aluminium
- finish: aluminium glass shot blasted
- painted in a RAL-colour upon re-quest
- swirl diffuser in galvanised steel, painted black
- dirt basket in galvanised steel

Specifications description

Example:

Floor grille with horizontal swirl air pattern, used for mounting in system floors. Floor grille and outer ring out of aluminium (glass shot blasted) and with removable grille tile. Equipped with a dust basket that can be used as damper.

Type: VMH11
size ... mm

Fixing

Outer ring is fixed to the floor with 3 mounting straps

How to order

VM011 size 200 mm

V	M	H	1	1	-	-	0	2	0	0
---	---	---	---	---	---	---	---	---	---	---

nom. diameter
(mm)

-: anodised aluminium

1: with mounting straps

1: with dust basket (damper)

V: vertical air pattern
H: horizontal air pattern